

The Circular Problem

In this chapter, you will learn the following to World Class standards:

1. Using the Entity Snap Settings to set the Center Esnap
2. Using a series of Circle commands, both diameters and radius
3. Using the Zoom Extents command to display the entire drawing
4. Use the Offset command to draw a circle
5. Adding centerlines using the Line command
6. Using the Move Command to Place Circles in Appropriate Position
7. Using the Copy Command to Add a Circle in an Proper Position
8. Using the Line Command to Add Details
9. Using the Move Command to Add Details
10. Using the Offset Command to Add Details
11. Using the Fillet Command to Join Two Lines not Intersecting
12. Using the Trim Command to Convert Construction Lines
13. Using the Object Properties Toolbar to Change an Entity's Layer
14. Using the Array Command to Create Circular Patterns
15. Using the Erase Command to Remove Lines

The circular problem is the second problem in your training and it is just as important to achieve the drawing standards covered here as it was in the rectangular problem. Where the rectangular problem is an instruction of basic concepts in straight lined and minor curved components, the circular problem addresses the unique challenges of mostly circular parts. The circular problem allows you to learn more skills early in your CAD drawing career, but also reinforces many concepts from your first lesson. It is this repetition that allows you to attain the World-Class standard.

Drawing circles using Entity Snaps

Setting Entity Snaps allows you to select points precisely. Pick the ESnap Settings tool on the Object Snap toolbar (the magnet). In the circular problem, you need to select the Center Entity Snap Mode for grabbing the center point of a circle, recognized by an orange circle when selected (Figure 5.1).

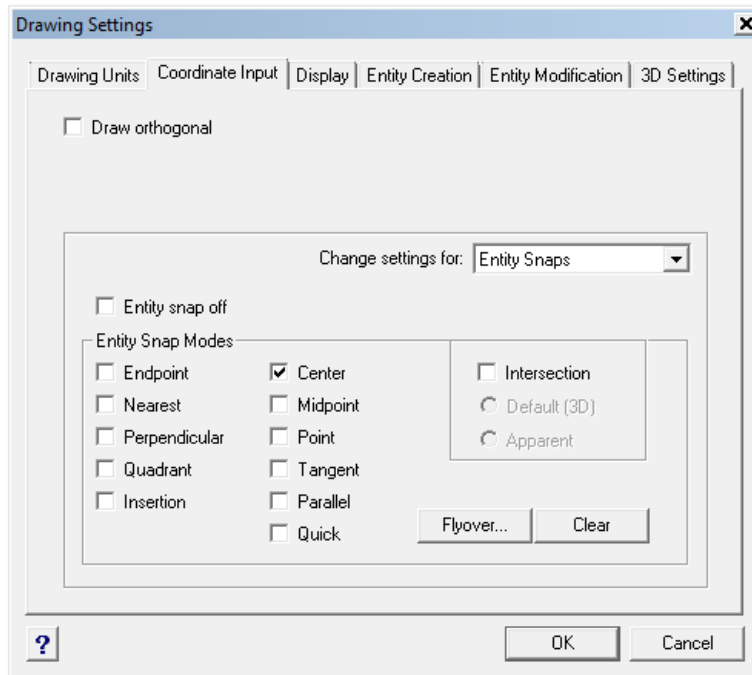

Figure 5.1 – Setting Center Esnap Setting

In the Circular problem, as in many drawings, it is essential that layers be created before any drawing begins. You will find that we will not have to return to change drawing entities later if the objects are placed on the correct layer, especially when there are arrays involved.

Creating Layers in an AutoCAD Drawing

You are already familiar with the concepts of layers from when you created layers in the Rectangular problem. Remember, you will draw the object lines on layer 0, the AutoCAD default layer, which is automatically set when a new file begins. You can see the current layer listed in the Layer Control list box in the Layers toolbar (Figure 5.2). To create new layers using the Layers Properties Manager, select the Layers command button to the left of the Layers Control list box.



Figure 5.2 - The Layers section of the Entity Properties toolbar

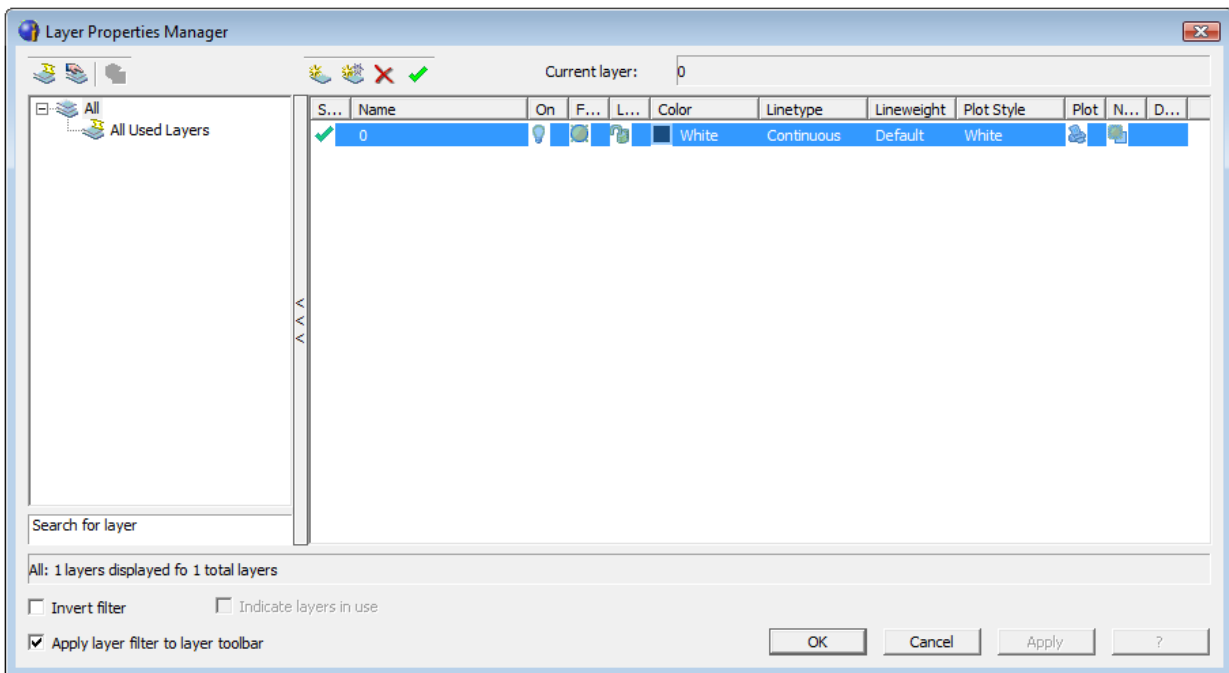

Figure 5.3 - The Layer Properties Manager window

To create this drawing, you need make three new layers: the Dimension layer for dimensions, the Center layer for centerlines, and the Text layer for text and notes. To create the layers, select the New button to add a new line ready for editing under the 0 layer (Figure 5.3). Immediately, the layer name is ready for entry, so type “Center” and ENTER twice to add another new layer. Type “Dimension” and ENTER twice to add another new layer. Type “Text” and ENTER once to finish adding new layers. Next you need to add different colors to help distinguish between your layers. To change colors, place your mouse arrow over the color box in the Dimension layer row and single left click with your mouse. The Color window will appear in front of the Layers Properties Manager (Figure 5.4). Select red from the Standards Colors row and select the OK button. You will now see that Dimension layer is red. Repeat the process to make the Center layer green and the Text layer blue.

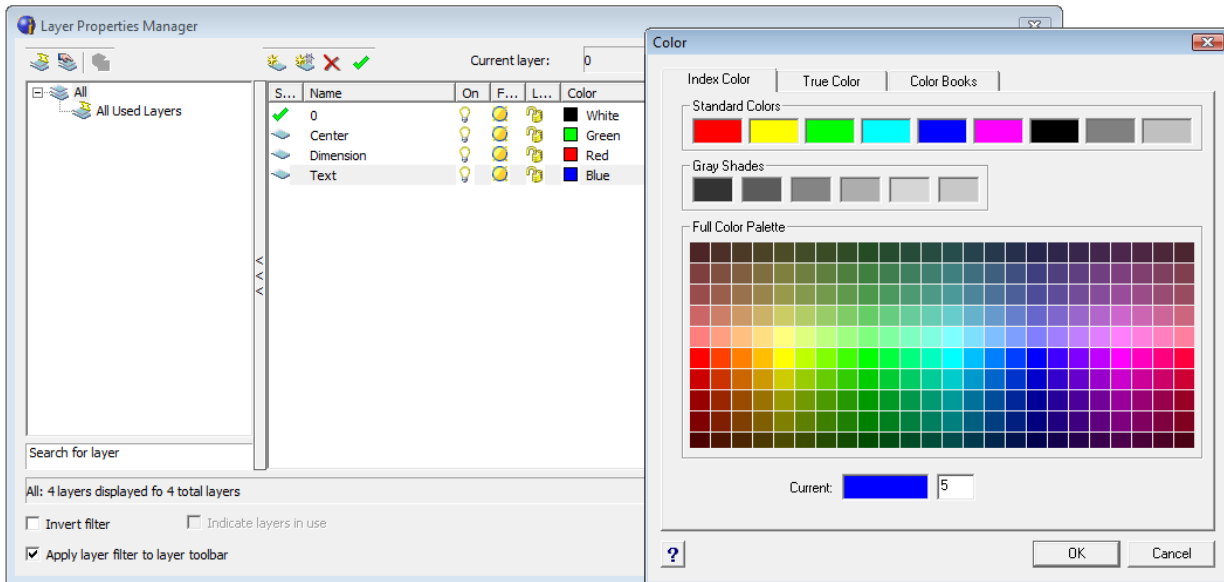

Figure 5.4 - The Color window

To finish creating and modifying layers, you need to change the center layer’s linetype from Continuous to Center. Place your mouse arrow over the text “Continuous” in the Center layer row and single left click with your mouse. The Linetype window will appear in front of the Layers Properties Manager (Figure 5.5). Scroll down, highlight the CENTER2 linetype as shown in Figure 5.5, and select the OK button. You will now see that the Center layer has a CENTER2 linetype (Figure 5.6).

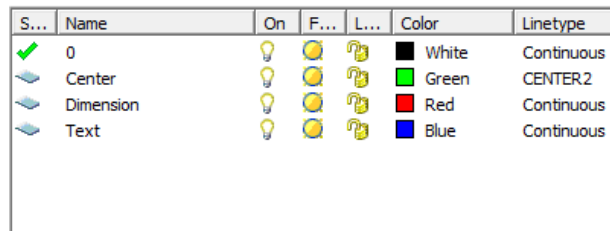
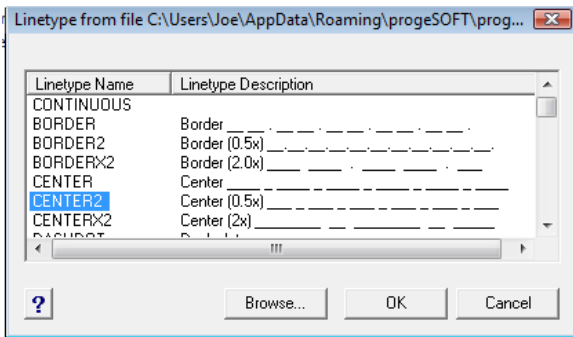

Figure 5.5 - The Select Linetype window **Figure 5.6 - The Center layer’s new linetype**

There is one more small step you must follow so that the linetype appears properly on your display. Exit the Layer Property Manager, and then find Drawing Settings under Tools on the Menu Bar. When the Drawing Settings window appears, select the Entity Creation tab, and in this section find global linetype scale. Change the 1 to a 0.1 (Figure 5.7); this will make the CENTER2 linetype pattern appear more often, and you will be able to see it when you move entities to the Center layer.

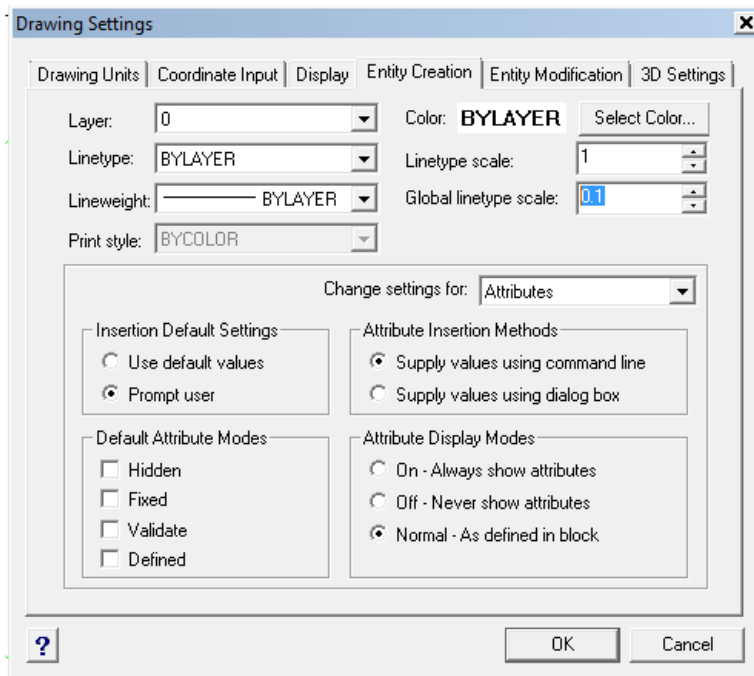

Figure 5.7 - Load or Reload Linetypes

The strategy in doing the Circular problem is to draw the perimeter circle first to define the outside of the drawing. Next, draw in the other circles, then place in the centerlines, and move all circles in their proper position. Finish drawing all the minor details as slots and keyways. Circular drawings that have repeating patterns will be constructed with arrays. In this problem, you will use three arrays to efficiently lay out object and centerlines. As in the Rectangular problem, you will reinforce the lessons of dimensioning and placing notes on the drawing. This drawing is also a timed problem, where the time to use the tools will represent your understanding and ability to operate the individual functions. So now let's draw the Circular problem.

Drawing circles using Entity Snaps

You need to draw a series of five circles using the Circle command that have the following diameters; 12, 5, 2.5, 0.75, and 0.625. Then you will need to draw one circle with the radius of 4.4375. Finally, you will draw the last circle using the Offset command, which you will do in the next section of this problem.



To draw the first five circles, select the Circle command on the Draw toolbar and pick a center point randomly on the center of your display with the left mouse button. You need to type "d" for diameter when the command line prompts you with "Diameter/<Radius>". Then type "12" when the command line prompts you to specify the "Diameter of circle" (Figure 5.8). A 12-unit circle will appear on the display (Figure 5.9).

```
Command : _CIRCLE
2Point/3Point/RadTanTan/TTT/Arc/Multiple/<Center of circle>:
Diameter/<Radius>: d
Diameter of circle: 12
```

Figure 5.8 – Command line prompts for the 12 unit circle

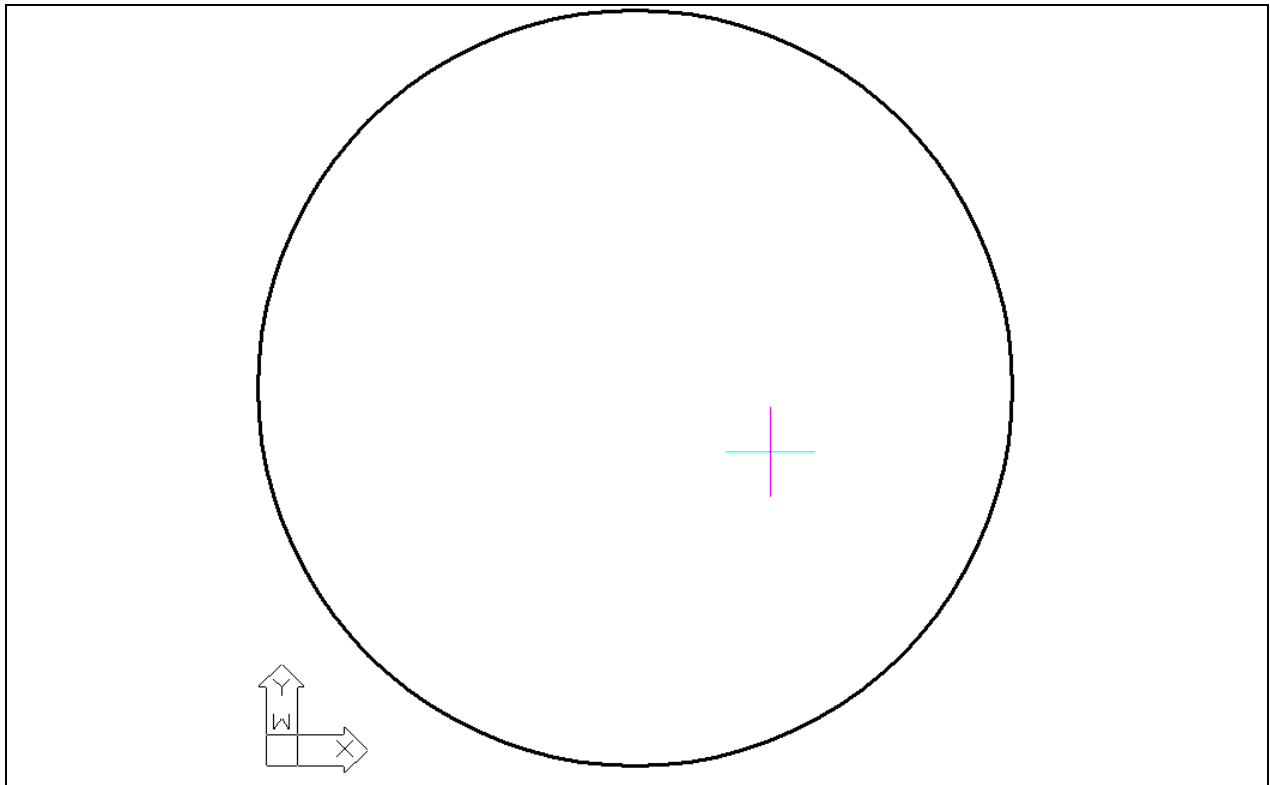

Figure 5.9 – The 12-unit Circle

Using the Zoom Extents Command to Display the Entire Drawing

The 12-unit circle may appear too small or large on your display, so you to use one of the zooming functions to fix the problem. Click and hold the Zoom Window tool on the Standard toolbar. It has a small black c in the lower right hand corner signifying that this is not just one tool, but a complete imbedded Zoom toolbar. Holding down on the Zoom tool will open the entire toolbar for you. Select the Zoom Extents tool (Figure 5.10) and the entire 12-unit circle will appear in the graphical display.



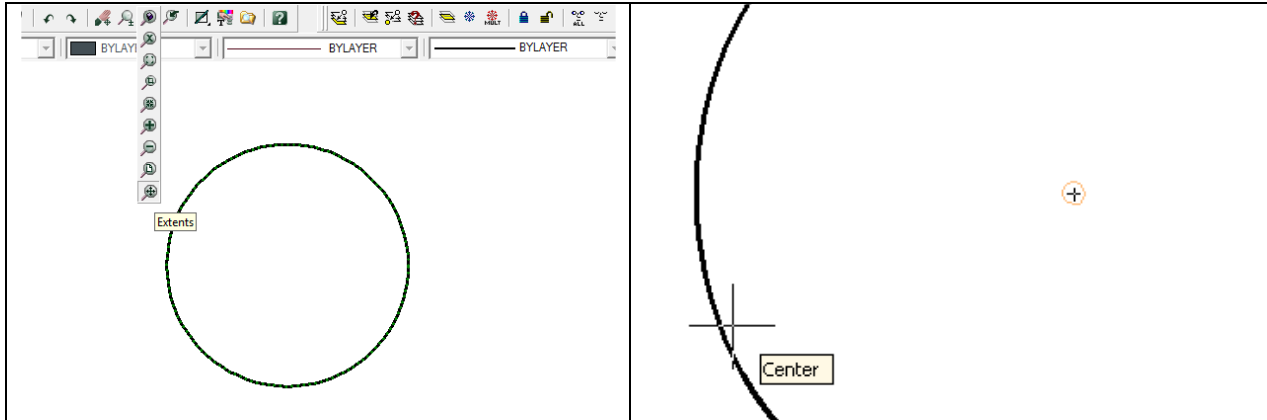

Figure 5.10 – Zoom toolbar

Figure 5.11 – Using the Center Esnap

Adding more Circles using the Diameter Option of the Circle Command

Next, select the Circle command on the Draw toolbar. Place the aperture cursor over the 12-unit diameter circle and a Center Esnap symbol (blue circle) will appear in the middle of the first circle drawn (Figure 5.11). Select the center point of the second circle by selecting with the left mouse button. You need to type “d” for diameter when the command line prompts you to specify the “Diameter/⟨Radius⟩:.” Then type “5” when the command line prompts you to specify the “Diameter of circle:.” Repeat the Circle command by pressing ENTER, and place the 2.5, 0.75, and 0.625 circles inside the 12-diameter circle having them sharing the same center points. There will be five concentric circles as shown in Figure 5.12.



You have been typing “d” for the diameter option, so you do not have to calculate the radius, which is half of the diameter. Some CAD technicians feel that they can make the mental calculation, so they can avoid the extra step. Some CAD operators will add the Circle Center Diameter tool, which is covered in World Class Advanced CAD. Many Architects and Engineers will create mark up drawings with diameters because diameters conform to better tolerance control. Remember, radius dimensions with normal company tolerances will change the part size by a factor of two. Try to use diameters whenever possible when drawing and dimensioning.

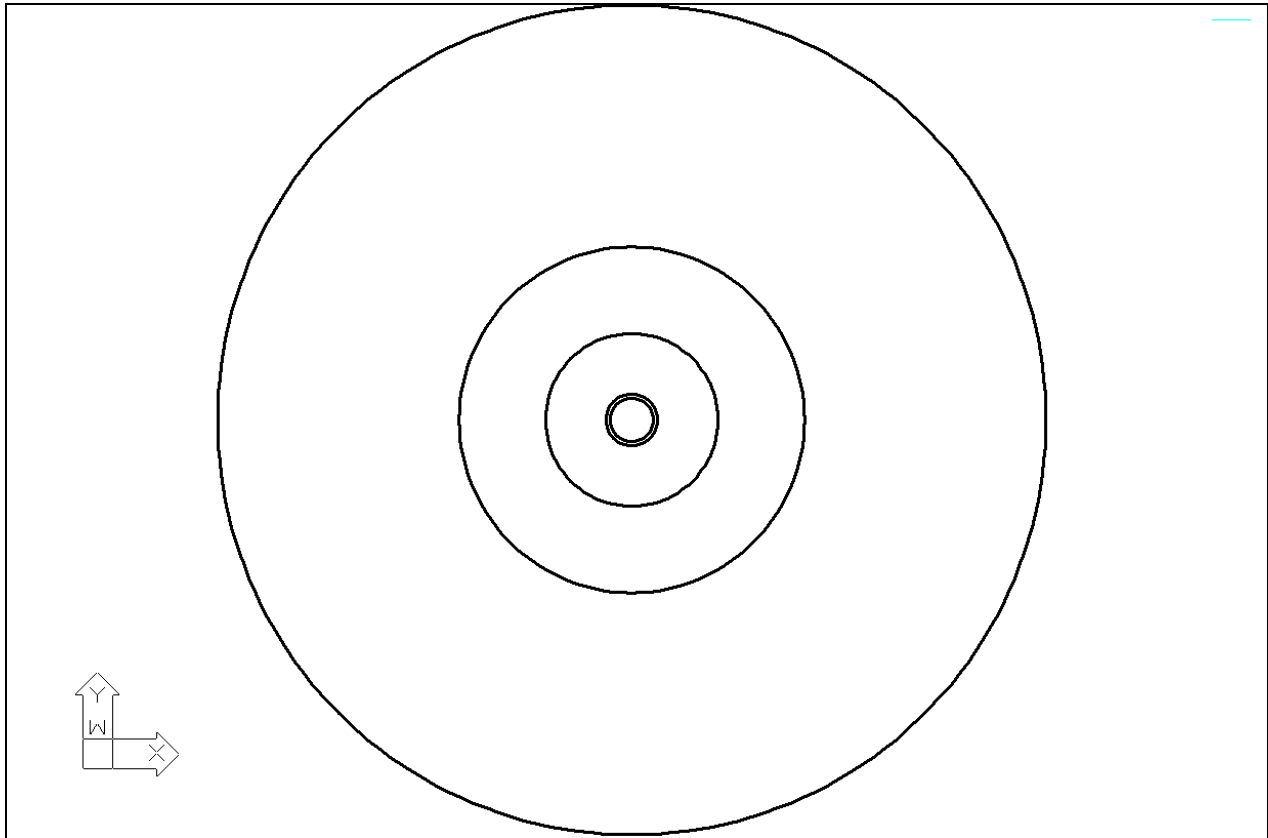

Figure 5.12 – Placing the 5, 2.5, 0.75 and 0.625 diameter circles in the drawing

Adding a Circle using the Radius Option of the Circle Command

You need to add a sixth concentric circle before you can move on. Begin by pressing ENTER to repeat the Circle command. Select the center point of this circle by placing the cursor over the 12-diameter circle and picking the same center point with the left mouse button. When the command line prompts you to “specify radius of circle or [Diameter]”, you need to type 4.4375 (Figure 5.13). A new circle will be drawn between the 5 and 12-diameter circle.



```
Command : _CIRCLE
2Point/3Point/RadTanTan/TTT/Arc/Multiple/<Center of circle>:
Diameter/<Radius> <0.313>: r
Enter a radius, pick a point, or choose the Diameter option:
Diameter/<Radius> <0.313>: 4.4375
```

Figure 5.13 – Command line prompts for the 4.4375 radius circle

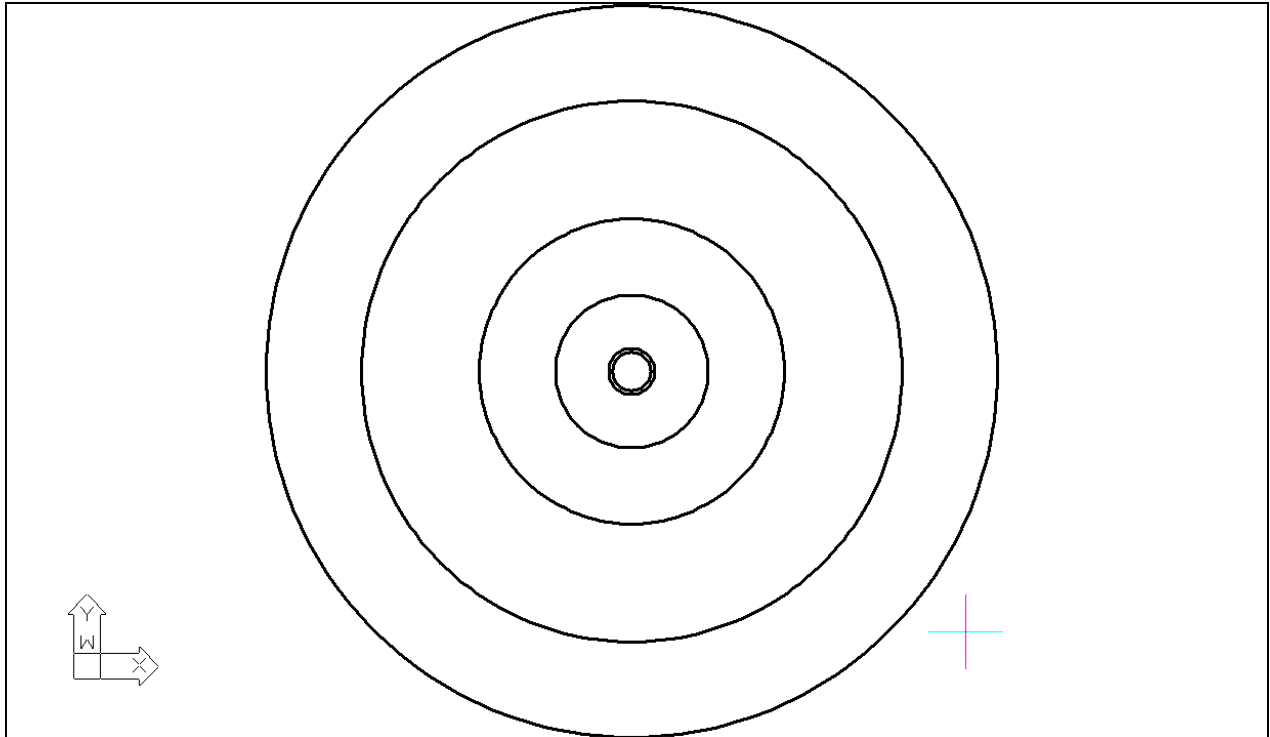

Figure 5.14 – The 4.4375 radius circle

Using the Offset Command to Add Another Circle

To add the seventh circle you are not going to use the Circle command, but rather you will use the Offset command on the Modify toolbar. Select the Offset tool and then select the 4.4375 radius circle you just drew. Next, you can specify the offset distance by typing 1.125 at the command line. With the Offset command you will have two choices: picking to the inside of the chosen circle or to the outside. In this problem, you will need to select to the outside of the 4.4375 circle. A new circle will be added to your drawing as shown in Figure 5.15. From the time you opened the new drawing until the seven circles are drawn, the timer has been running, so check your time by typing “Time” at the command line. Check your time against the World Class CAD standard and train yourself to draw this section of the Circular problem to time and with zero errors.



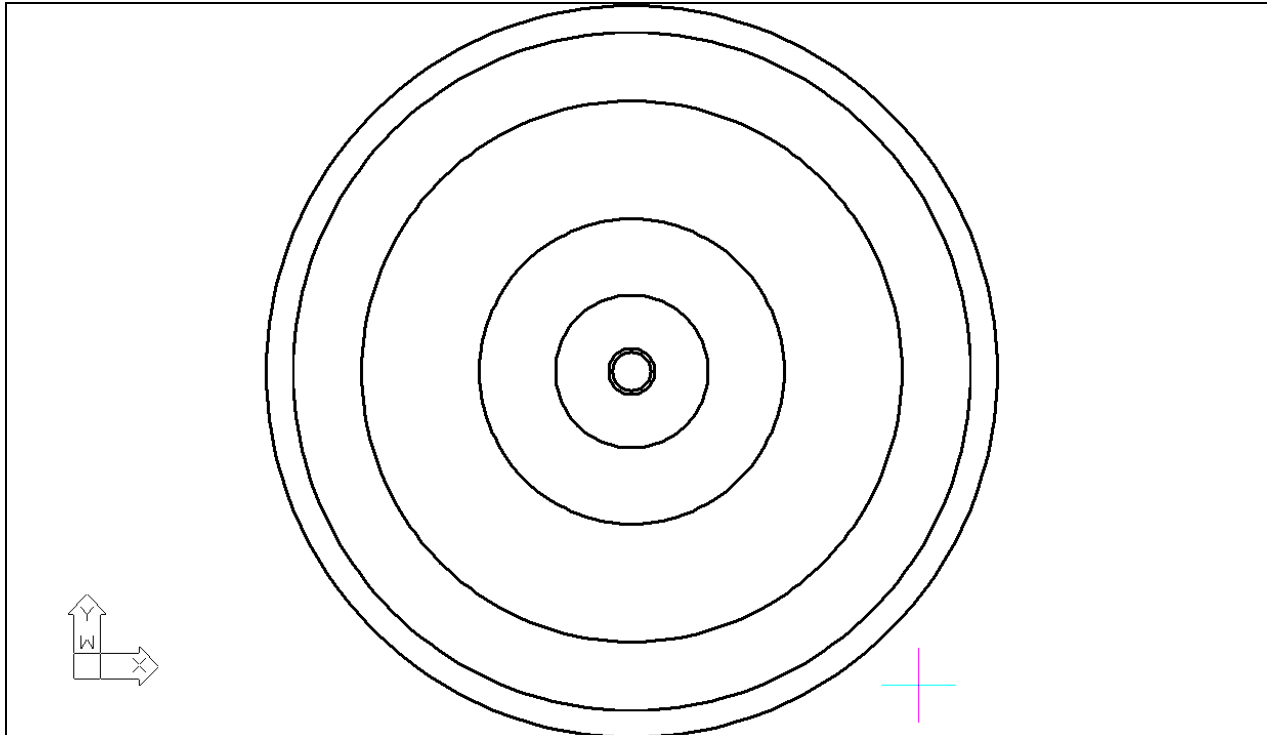

Figure 5.15 – Using the Offset command to draw the seventh circle

*** World Class CAD Challenge 100-10 * - Create a New file, create the three new layers, set the Entity Snap settings and draw the seven circles in 120 seconds. Continue this drill four times, each time completing the drawing under 120 seconds to maintain your World Class ranking.**

Adding Centerlines to the Drawing Using the Line Command

Just like the Rectangular problem, centerlines are used to show symmetry and are added to assist in drawing and dimensioning. A CAD technician would draw the centerlines from quadrant to quadrant of the 12-unit circle if he/she were following the strategy utilized in the Rectangular problem. Since the polar or circular array will be employed in this construction technique, you will only need to draw a single quadrant of the centerline, which will then be copied and rotated using the Array command on the Modify toolbar.



First, zoom in closer to your work by using the Zoom Window command on the Standard toolbar. After selecting the Zoom Window tool, specify the first corner and the opposite corner, picking two points that will make a window similar to the one shown in Figure 5.16.



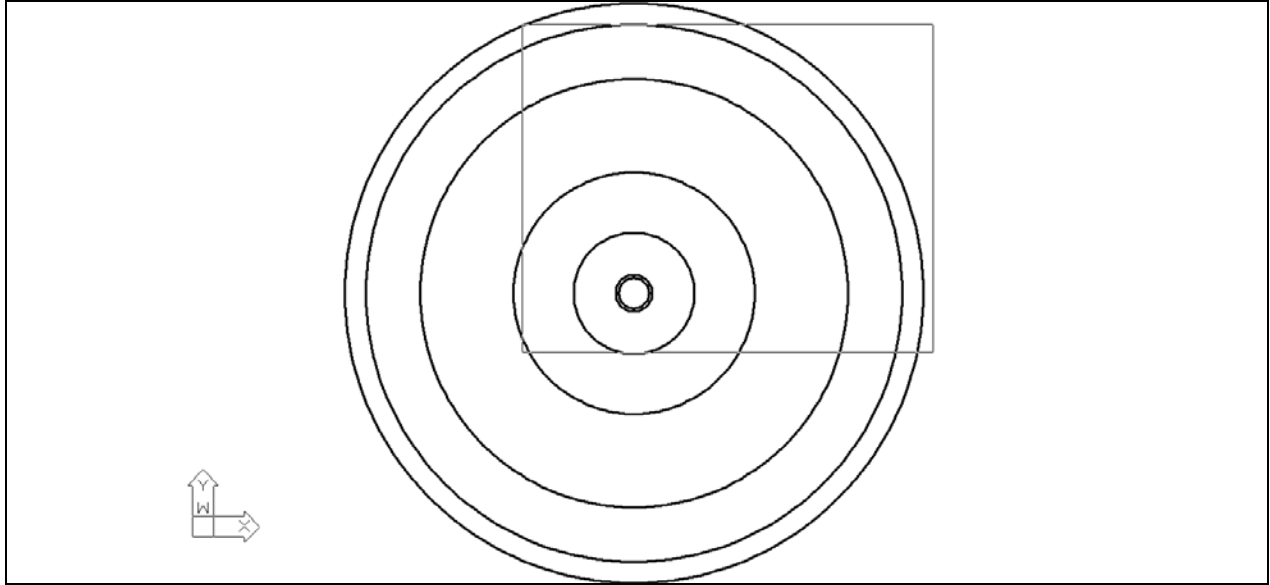
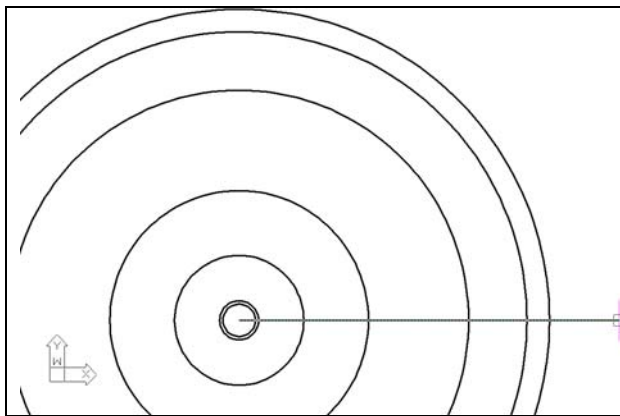
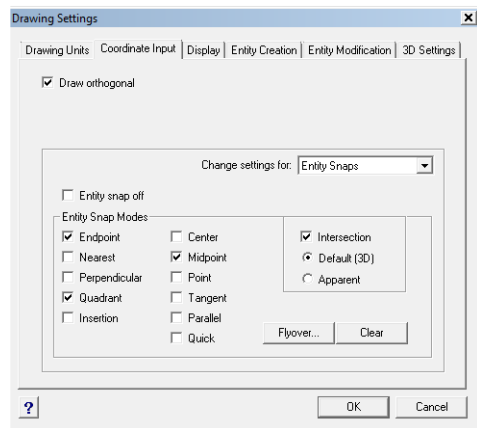

Figure 5.16 – Using the Zoom Window command to get in close to your work



Select the Line command on the Draw toolbar. Select the first point of the line by placing the mouse cursor on top of any circle, thereby causing the Center ESnap to appear, and then select the center with the left mouse button. The second point will be located roughly 0.25 units past the outside circle. Ensure that the Ortho setting is on, enabling lines to only be drawn in horizontal or vertical mode. The center line should look like the one shown in Figure 5.17.

Figure 5.17 – The horizontal centerline



Expert operators trained in the World Class CAD techniques will change the ESnap settings from time to time in a drawing to save time. Select the ESnap Settings tool on the Object Snaps toolbar. Press the “Clear” button on the Drafting Settings window and then “check” the Endpoint, Midpoint, Quadrant, Intersection, and Perpendicular Entity Snaps. Then select “OK” to confirm the changes (Figure 5.18).



Figure 5.18 – Changing the Entity Snap Settings to Maintain Drawing Efficiency

Using the Move Command to Place Circles in Appropriate Position

The 0.625- and 0.75-diameter circles need to be moved into their appropriate position using the Move command. After selecting the Move tool from the Modify toolbar, select the 0.75 circle. You will be prompted to continue to select entities, so press ENTER to proceed to the second part of the Move command.

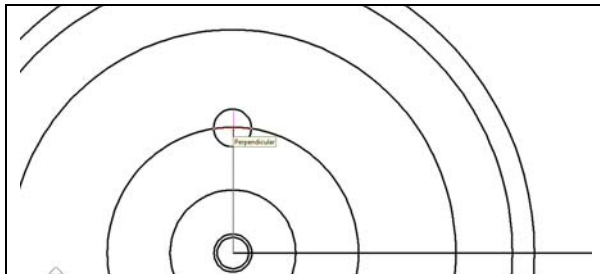

At the prompt “Vector/<Base point>:,” select the endpoint of the centerline, which represents the center of the part. The “second point of displacement” is the north quadrant of the 2.5-unit circle. After picking the second point, notice that the 0.75 circle is now centered on the north quadrant of the 2.5-unit circle (Figure 5.19).

Figure 5.19 – Moving the 0.75 circle

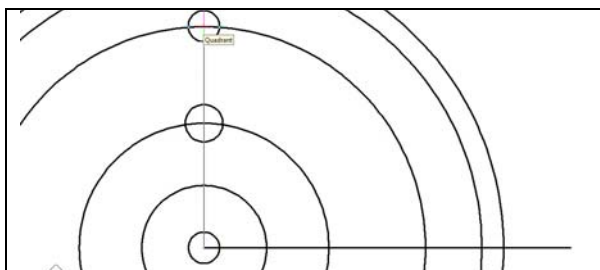

You need to move the 0.625 circle to the 4.4375 radius circle using the same technique: selecting the 0.625 circle, ENTER, selecting the Endpoint of the centerline, and then the north quadrant of the 4.4375 radius circle. Now the 0.625 circle is moved to the north quadrant as shown in Figure 5.20.

Figure 5.20 – Moving the 0.625 circle

Using the Copy Command to Add a Circle

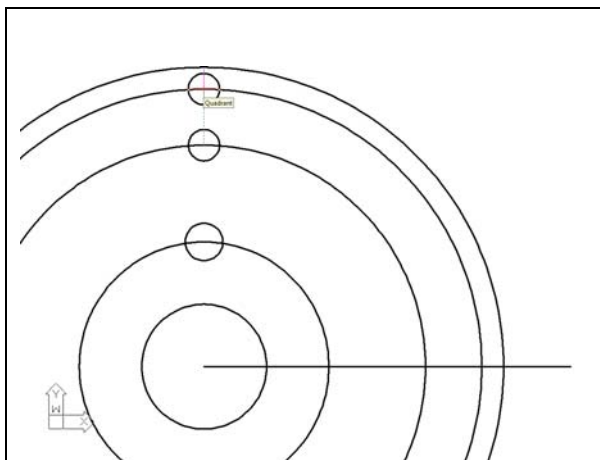

To create a slotted hole in this part, you need to copy the 0.625 circle to the north quadrant of the next circle. Select the Copy tool on the Modify toolbar. After selecting the circle, press ENTER to proceed to the second stage of the Copy command. For the first base point, pick the quadrant at the center of 0.625 circle and for the second base point of displacement pick the quadrant of the circle that is 1.125 to the outside, as shown in Figure 5.21.

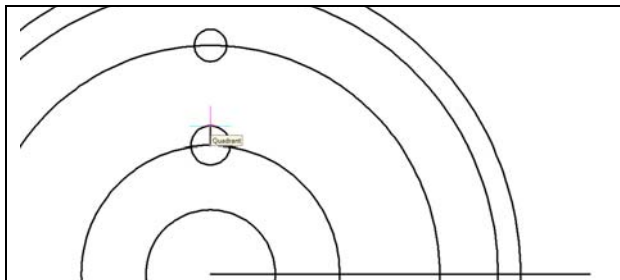

Figure 5.21 – Copying the 0.625 circle

*** World Class CAD Challenge 100-11 * - Create a New file, create the three new layers, set the Entity Snap settings and draw the seven circles, move and copy the two circles in 140 seconds. Continue this drill four times, each time completing the drawing under 140 seconds to maintain your World Class ranking.**

Using the Line Command to Add Details

You will now use a series of lines in your circular part to add details such as centerlines, the slotted hole, and a keyway to prevent the part from slipping during rotation. First you will draw a centerline for the 0.75 circle. In the Rectangular Problem, you used the center mark provided on the Dimension toolbar. The center marks have two lines perpendicular to each other and are appropriate in rectangular shapes, but in circular parts, center marks are a combination of straight lines intersecting the circular part's center and arced segments defining the distance from the part's center.



Draw a line segment by picking the Line tool on the Draw toolbar and pick the north quadrant of the 5.0 diameter circle. Draw a line to the north quadrant of the 0.75 circle as shown in Figure 5.22. Press ENTER to finish the line segment. Next, you will proceed to detailing the two 0.625 holes.

Figure 5.22 – Drawing a center mark

To continue forming the slotted hole, you need to draw lines from the tangent point of each circle. In most cases, the Quadrant ESnap tool will remain as a primary tool to draw slotted details. Draw a line segment by picking the Line tool on the Draw toolbar and picking the west quadrant of the lower 0.625 circle. Draw a line to the west quadrant of the upper 0.625 circle as shown in Figure 5.23. Press ENTER to finish the line segment.

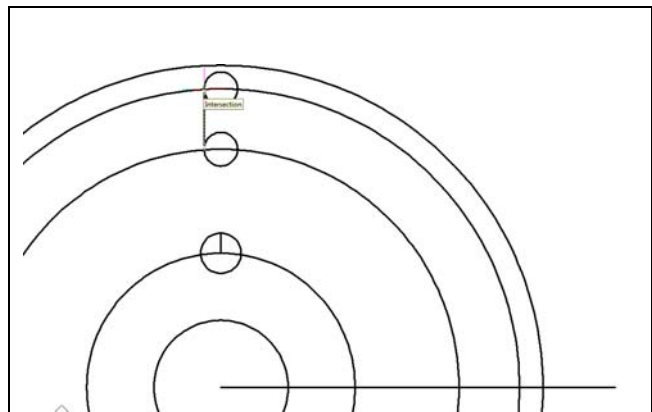

Figure 5.23 – Drawing the first slot line

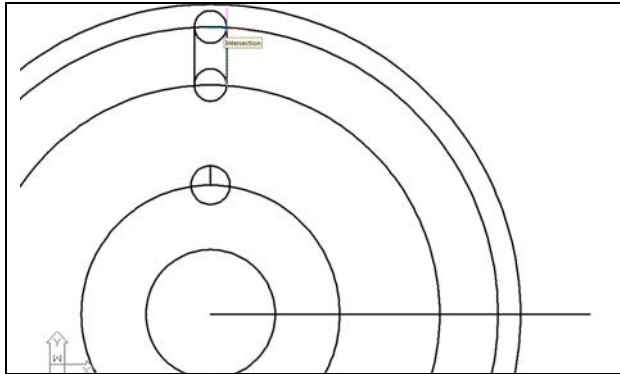

Figure 5.24 – Drawing the second slot line

Keyways are present on many circular parts, and in this case one half of a key would be in the shaft and the other in the circular part. The key prevents slippage during the rotation of the assembly. In Figure 5.25, you see a line segment of any length drawn vertically from the west quadrant of the 2.5 circle. Again, select the Line tool; pick the west quadrant of the 2.5 circle for the first point and any point vertically above the first.

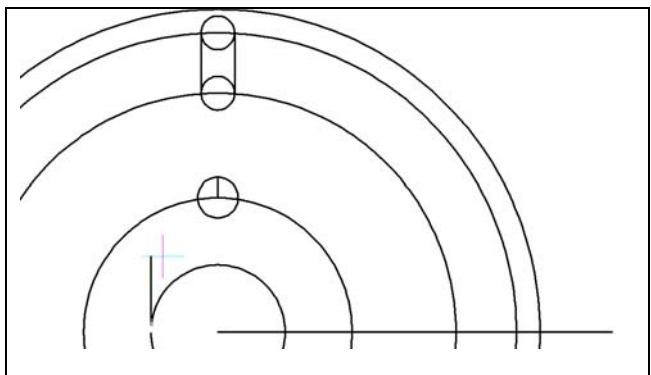

Figure 5.25 – Draw the keyway line

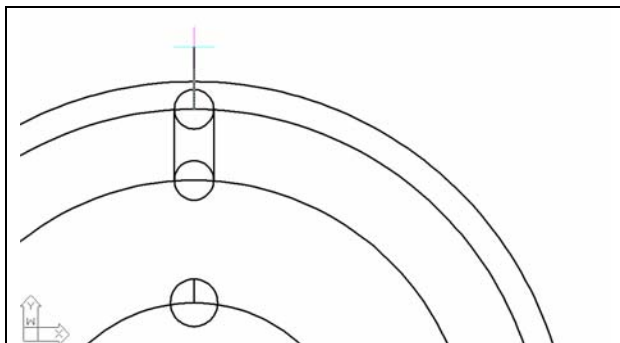

Figure 5.26 – Drawing a construction line

The top of the slotted hole at the crown of the circular part will be open, so you will draw a centerline to construct the detail. Select the Line tool on the Draw toolbar, picking the north quadrant of the top 0.625 circle's centerline for the first point. For the second point of the line, pick any point above the perimeter of the outside circle (Figure 5.26).

Using the Move Command to Add Details

As you continue to learn to group commands for efficient computer aided drawing, you need to move the keyway line into position.



Select the Move tool on the Modify toolbar and select the keyway line and ENTER to proceed to the second stage of the Move command. Next you will be prompted to select the base point or displacement. Pick a point in any open area on the viewing screen where your Entity Snaps will not interfere with the command. After that, move the line to the right with your mouse to orient the direction of the placement and type 2.687 and ENTER. The keyway line is now in the appropriate location (Figure 5.27).

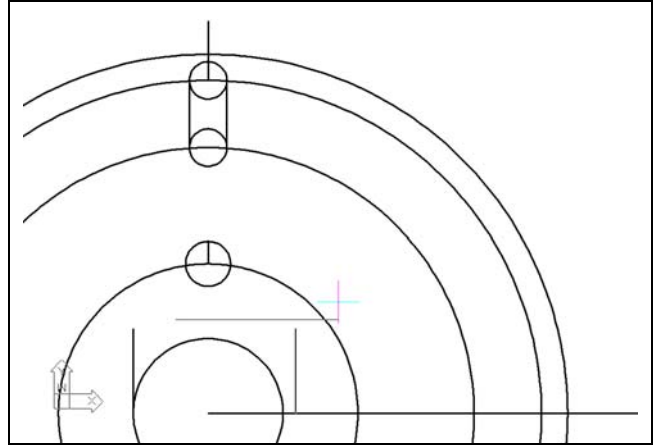

Figure 5.27 – Moving the keyway line

You need to reposition the centerline drawn on the 0.75 circle by selecting the Move tool on the Modify toolbar and ENTER. You will be prompted to select the base point or displacement. Pick the midpoint of the centerline using the Midpoint Entity Snap that is automatically loaded in the Entity Snap Settings window. After that, move the line down with your mouse and pick the Endpoint Entity Snap and ENTER. The centerline is now in the proper location (Figure 5.28).

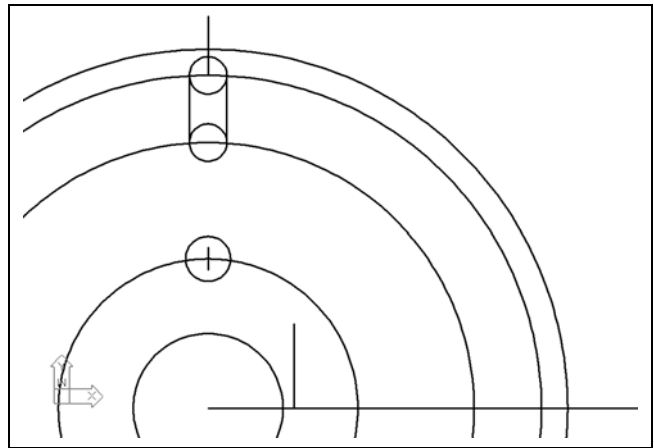

Figure 5.28 – Centering the center mark

Using the Offset Command to Add More Detail

When your initial lines are drawn accurately then a command such as Offset will add additional detail to the drawing without the numeric baggage associated with the base Line command.



It just so happens that the width of the slot breakout from the centerline and the distance of the keyway width from the centerline is the same measurement of 0.1875. Select the Offset tool on the Modify toolbar and type 0.1875 for the offset distance and ENTER. Next select the keyway centerline and then pick above it to copy a line 0.1875 above the original line. In the same Offset command, select the keyway centerline again and then pick below it to copy a line 0.1875 below the centerline.

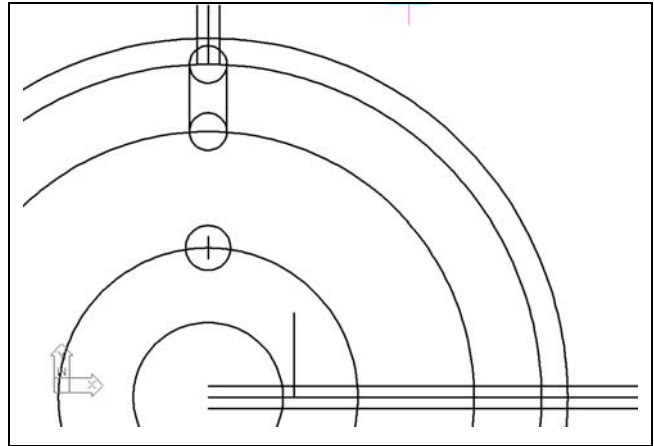

Figure 5.29 – Offsetting lines

You do not have to exit the Offset command to open up the top of the slotted hole, since the detail has the same offset distance. Select the slotted hole's centerline and then pick to the left of the centerline to copy a line 0.1875 to the left. Yet again, in the same Offset command, select the slotted hole's centerline and then pick to the right of the centerline to copy a line 0.1875 to the right. (Figure 5.29)

*** World Class CAD Challenge 100-12 * - Create a New file, create the three new layers, set the Entity Snap settings and draw the seven circles, move and copy the two circles, and add lines for the keyway and slotted holes in 190 seconds. Continue this drill four times, each time completing the drawing under 190 seconds to maintain your World Class ranking.**

Using the Fillet Command to Join Two Lines not Intersecting

The fillet command, when the radius is set to zero, becomes an effective trimming and joining tool. You will form the keyway with the Fillet tool. This is the first time you will use the Fillet command to join two line segments that could intersect, but do not.

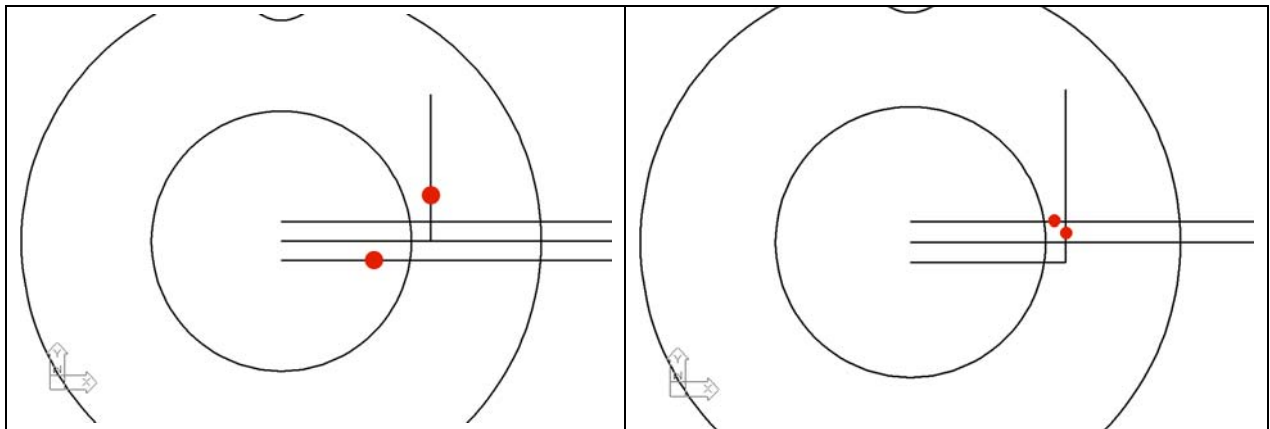

Figure 5.30 – Forming the key by filleting

Figure 5.31 – Forming the key by filleting

In Figures 5.30 and 5.31, zero radius corners are created by filleting the keyway and keyway offset lines. Select the Fillet command on the Modify toolbar, and type “R” and ENTER to allow you to set the radius. Type “0” and ENTER. As in Figure 5.32, select the lower offset line and the keyway line to form the first corner. To repeat the Fillet command, press ENTER and select the top keyway offset line and the keyway line.

Using the Trim Command to Convert Construction Lines

In efficient Computer Aided Design, you will use construction lines to create a new drawing, but what differentiates the World Class CAD method from other training courses is the conversion of construction lines into object lines. Therefore you will rarely find yourself erasing unnecessary lines, arcs or circles.

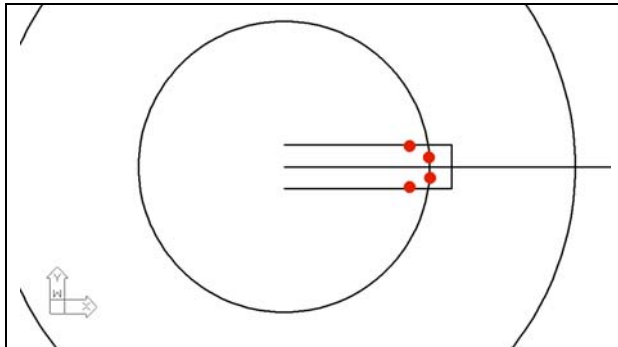

To remove the two line segments entering the 2.5 diameter circle and open the circle to the 0.375 key width, use the Trim tool on the Modify toolbar. Press ENTER to make every object line a cutting line. Now make four selections, the two-keyway centerline offset lines entering the 2.5 diameter circle, and the two arc segments between the two offset lines. (Figure 5.32)

Figure 5.32 – Forming the key by filleting

To create the slot shown in Figure 5.34, you need to remove ten line and arc segments. Repeat the Trim tool on the Modify toolbar. Then press ENTER to make every object line a cutting line. Now make the ten selections as shown in Figure 5.33.

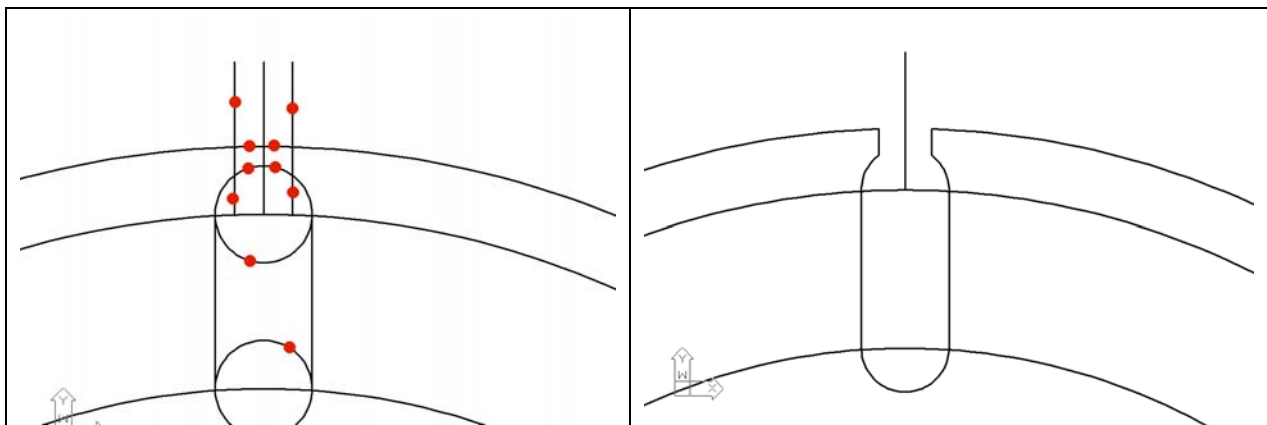

Figure 5.33 – Detailing the slot with Trim

Figure 5.34 – The detailed slot

Using the Object Properties Toolbar to Change an Entity's Layer

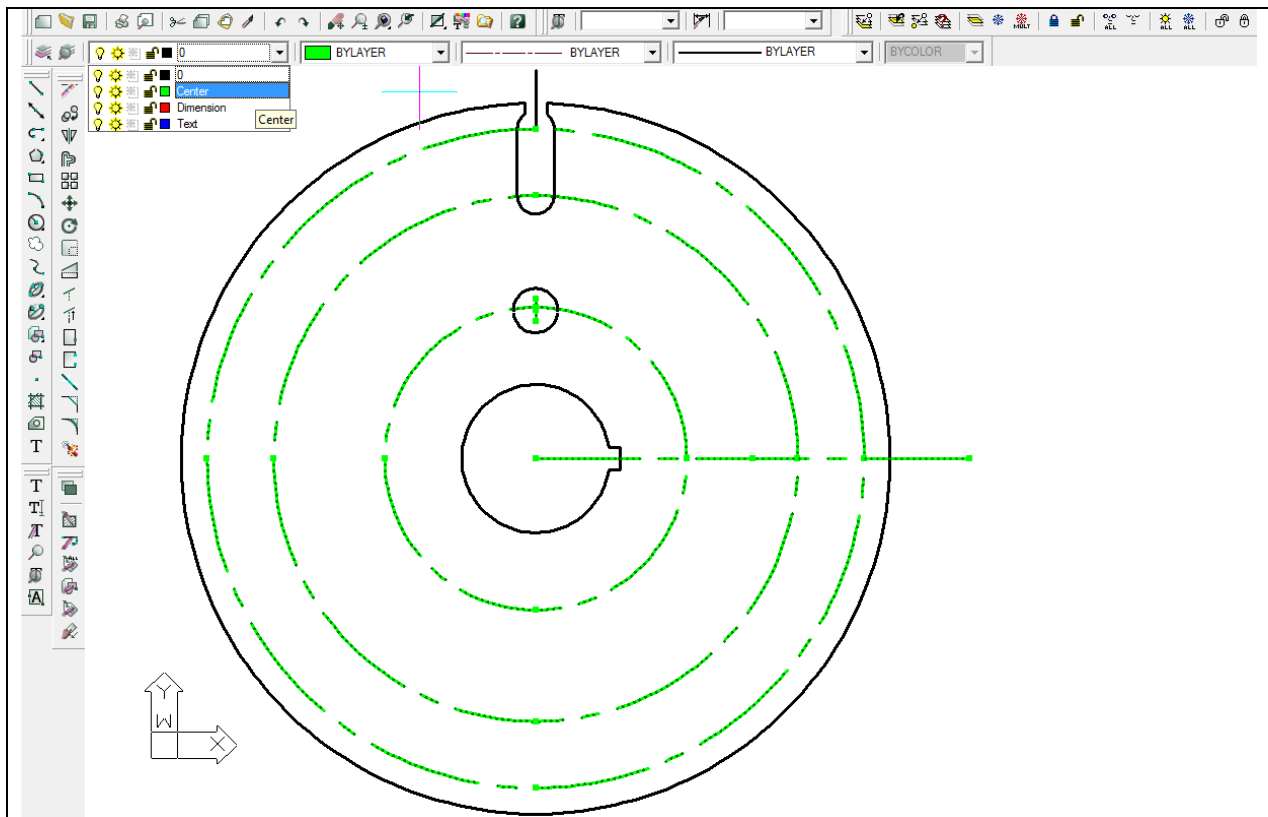

Figure 5.35 – Objects moved to Center layer

You may have already noticed by accident that drawing entities, such as lines, arcs and circles can be selected prior to choosing a progeCAD tool. In a situation where you need to place certain line and circle entities on the Center layer, the selections are made first. Select all three middle circles, the single centerline and the 0.75 circle's centerline. In the Layer Selection window on the Object Properties toolbar that is presently displaying layer "0," select the Center layer. You will notice the selected entities will turn green, which the color that was assigned to the Center layer. Press the "ESC" key to remove the entities from the selection set.

Using the Array Command to Create Circular Patterns

Changing the entities to the proper layer will save time, since the Array command will create multiple copies of lines and circles many times over. In the Rectangular problem, you were exposed to the rectangular array. Now you will perform four separate polar arrays, the first of which is to copy the 0.75 diameter circle and centerline six times. After erasing unneeded vertical centerlines, you will conduct a second polar array of the major centerline. The third array will both rotate and copy



the slotted hole and vertical centerline twenty degrees counterclockwise. After erasing superfluous lines and arcs, the fourth polar array will finish a complex circular part containing hundreds of entities.

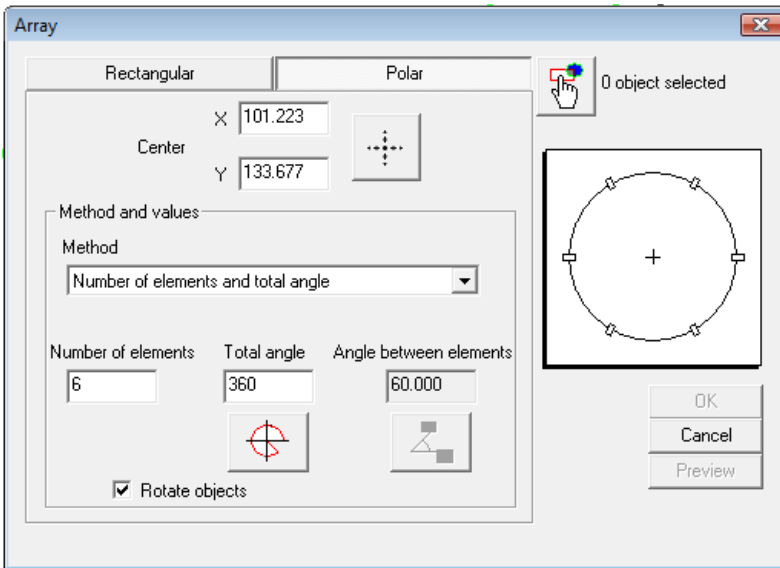

Select the Array tool on the Modify toolbar and the Array window (Figure 5.36) will appear. Select the Polar option and then the 0 Objects Selected button. Select the 0.75 diameter circle and its centerline on the display screen and hit ENTER to return to the Array window. Next, select the Center button, which brings you back to the drawing to select the center of the array.

Figure 5.36 – The polar array of the 0.75 circle and centerline

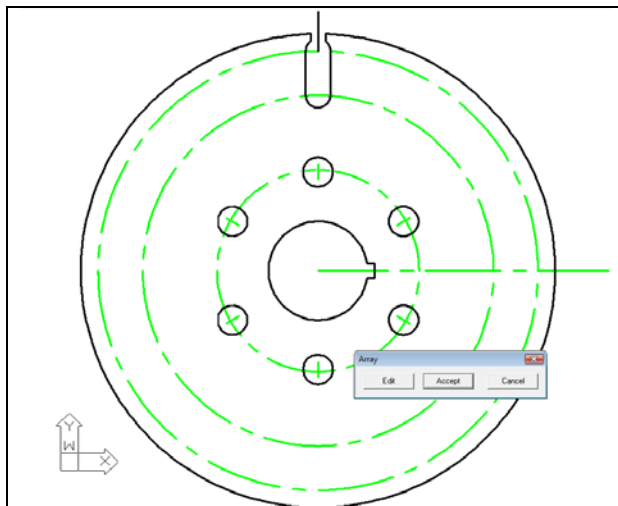

Pick the center of the part by selecting the Endpoint of the centerline that is also the center of the part. Change the “Number of Elements” textbox to “6” and select the Preview button. The array will be shown on the display screen, along with an Array Edit, Accept, or Cancel window. If the Circular problem looks like Figure 5.37, press the Accept button and the array will be completed. If the Circular problem does not look like Figure 5.37, press the Modify button repeat the array process.

Figure 5.37 – Array the 0.75 circle

Using the Erase Command to Remove Three Lines

When creating a drawing that will result in a complex Computer Aided Design image, you will find out many weeks from now that having a smaller line segment hidden below on object or dimension line can cause problems. You have arrived at a moment when it is necessary to erase two centerlines and a construction line.



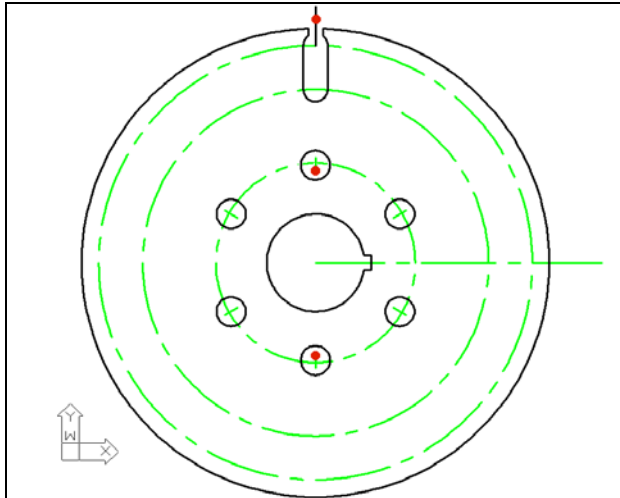

Figure 5.38 – Erasing three lines

Select the Erase tool on the Modify toolbar and select the three entities on the part as shown in Figure 5.38. This will remove any smaller centerlines that would be covered up by the main centerline. Next, you need to perform the second of the four arrays, copying and rotating the main centerline around the circular part.

Using the Array Command to Create More Circular Patterns

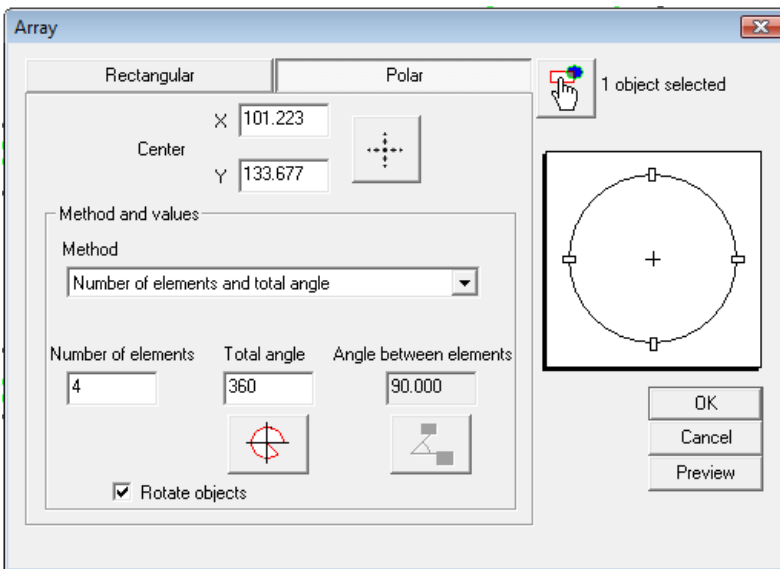
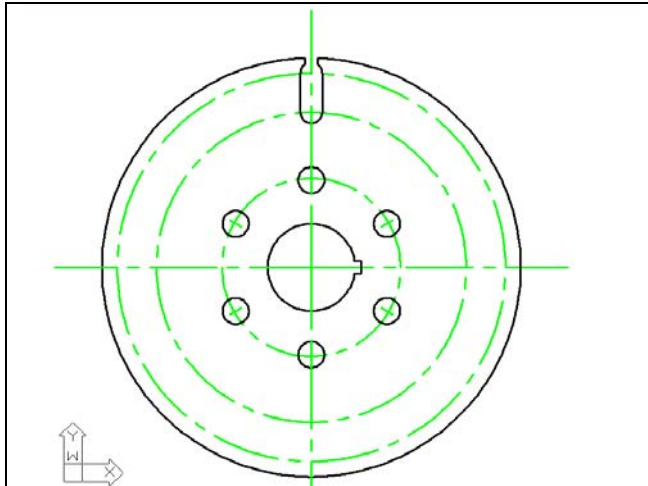

Figure 5.39 – The polar array of the main centerline

Again select the Array tool on the Modify toolbar to access the Array window (Figure 5.39). Select the Polar option, then the objects selected button. Select the main centerline on the display screen and hit ENTER to return to the Array window. Next, select the Center button, which will bring you back to the drawing to select the center of the part.



Pick the center of the part by selecting the Endpoint of the centerline that is also the center of the part. Change the “Number of Elements” to “4” and select the Preview button. The array will be shown on the display screen, along with an Array Edit, Accept, or Cancel window. If the Circular problem looks like Figure 5.40, press the Accept button and the array will be completed. If the Circular problem does not look like Figure 5.40, press the Modify button repeat the array process.

Figure 5.40 – Arraying the main centerline

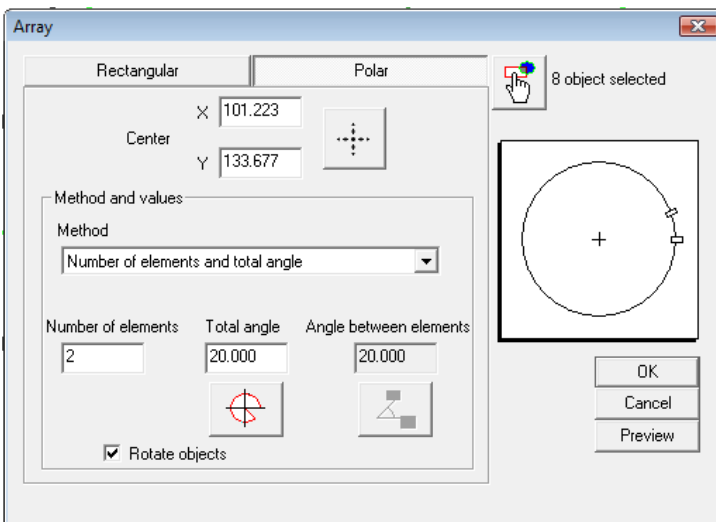

Select the Array tool once again on the Modify toolbar and the Array window (Figure 5.41) will appear. Pick the Polar option, then the objects selected button. Select the slotted hole using a selection window (Figure 5.42) on the display screen, and then top main centerline. Hit ENTER to return to the Array window.

Figure 5.41 – The polar array of the slotted hole

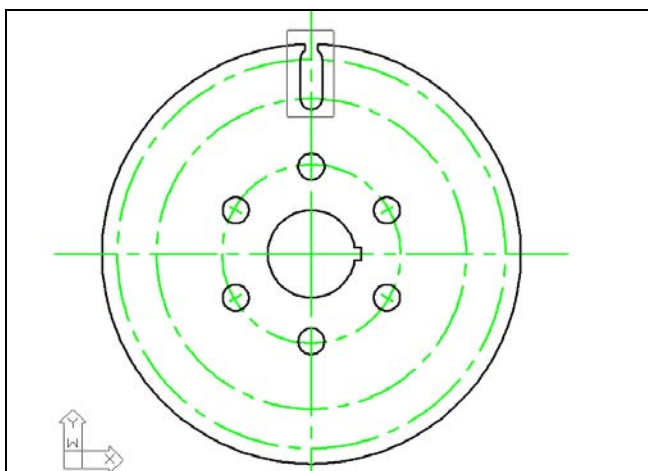

Next, select the Center button which will bring you back to the drawing to select the center of the part. Pick the center of the part by selecting the Endpoint of the centerline that is also the center of the part. Change the “Number of Elements” text box to “2” and the “Total Angle” text box to 20 degrees. Select the Preview button.

Figure 5.42 – Selecting the slot

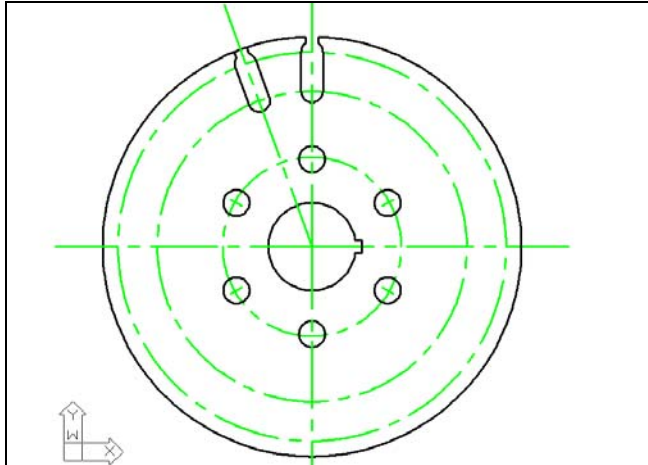

The array will be shown on the display screen, along with an Array Edit, Accept, or Cancel window. If the Circular problem looks like Figure 5.43, press the Accept button and the array will be completed. If the Circular problem does not look like figure 5.43, press the Modify button repeat the array process.

Figure 5.43 – Single array of slot

Using the Trim and Erase Command to Remove Arcs and Lines

Next select the Trim tool on the Modify toolbar and select the line to the right on the arrayed slotted hole (Figure 5.44). Press ENTER and select the outside 12.0 diameter circle anywhere to the left of the slot. After the circle is trimmed back to the right line of the slotted hole, select the Erase tool on the Modify toolbar and remove the arrayed slotted hole as shown in Figure 5.45.

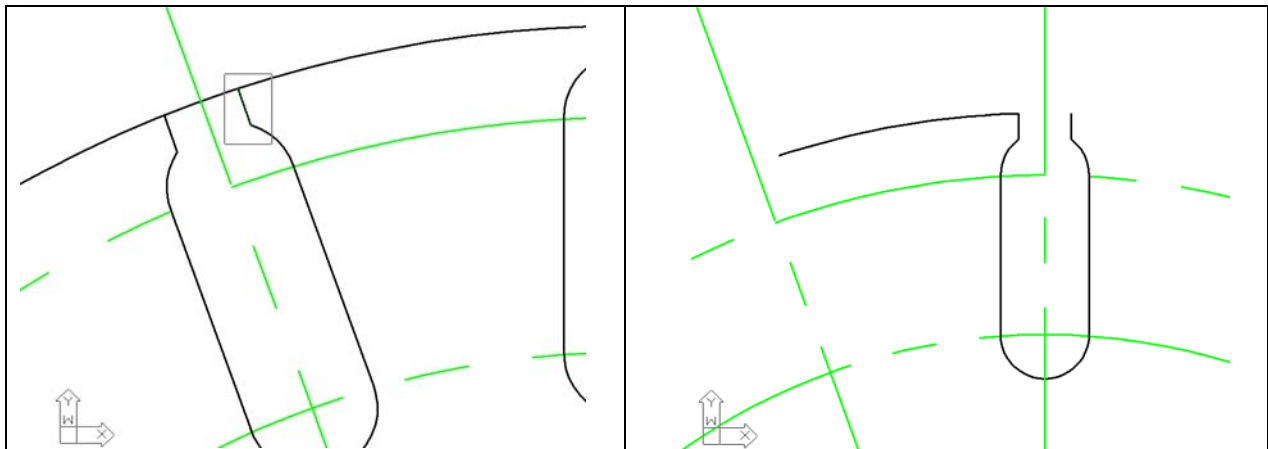
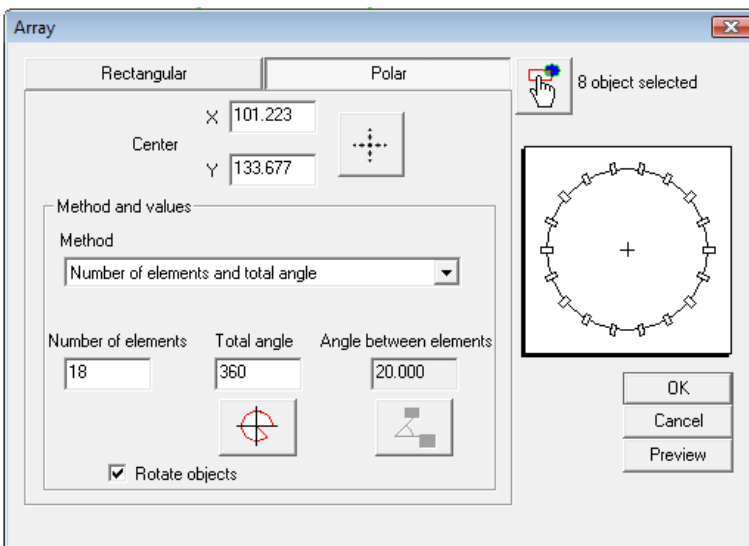

Figure 5.44 – Trimming the perimeter

Figure 5.45 – Erasing the second slot

With the initial slotted hole and the short arc that is attached to the left side, it is now time to complete the Circular problem and array this pattern 18 times.

Using the Array Command to Create More Circular Patterns



Select the Array tool on the Modify toolbar which to bring up the Array window (Figure 5.46). Pick the Polar radial option, then the Objects Selected button. Select the slotted hole using a selection window (Figure 5.47) on the display screen and the top main centerline. Hit ENTER to return to the Array window.

Figure 5.46 – The polar array of the 18 slotted holes

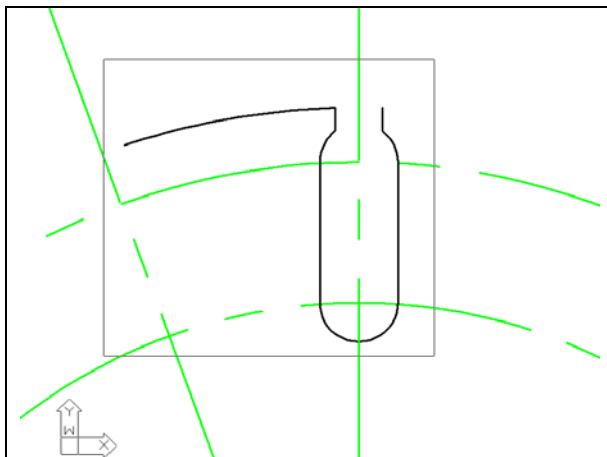

Next, select the Center button which will bring you back to the drawing to select the center of the part. Pick the center of the part by selecting the Endpoint of the centerline that is also the center of the part. Change the “Number of Entities” textbox to “18” and the “Total Angle” textbox to 360 degrees. Select the Preview button.

Figure 5.47 – Selecting for the final array

The array will be shown on the display screen, along with an Array Edit, Accept, or Cancel window. If the Circular problem looks like Figure 5.48, press the Accept button and the array will be completed. If the Circular problem does not look like figure 5.48, press the Modify button to repeat the array process.

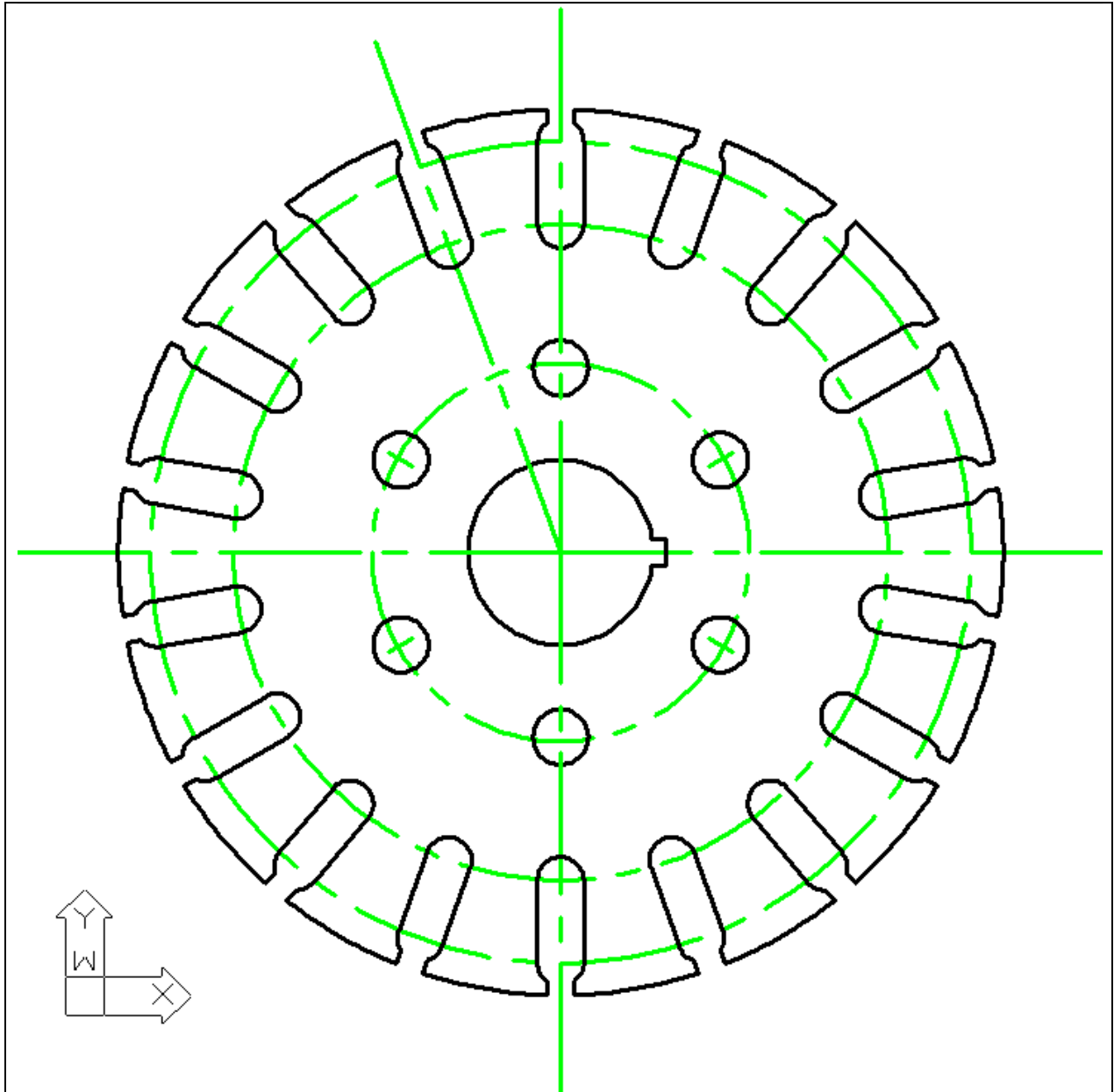

Figure 5.48 – The finished Circular problem

*** World Class CAD Challenge 100-13 * - Create a New file, create the three new layers, set the Entity Snap settings and draw the seven circles, move and copy the two circles, and add lines for the keyway and slotted holes, and do the four arrays in 5 minutes. Continue this drill four times, each time completing the drawing under 5 minutes to maintain your World Class ranking.**